

TRIPLE OFFSET
BUTTERFLY VALVE

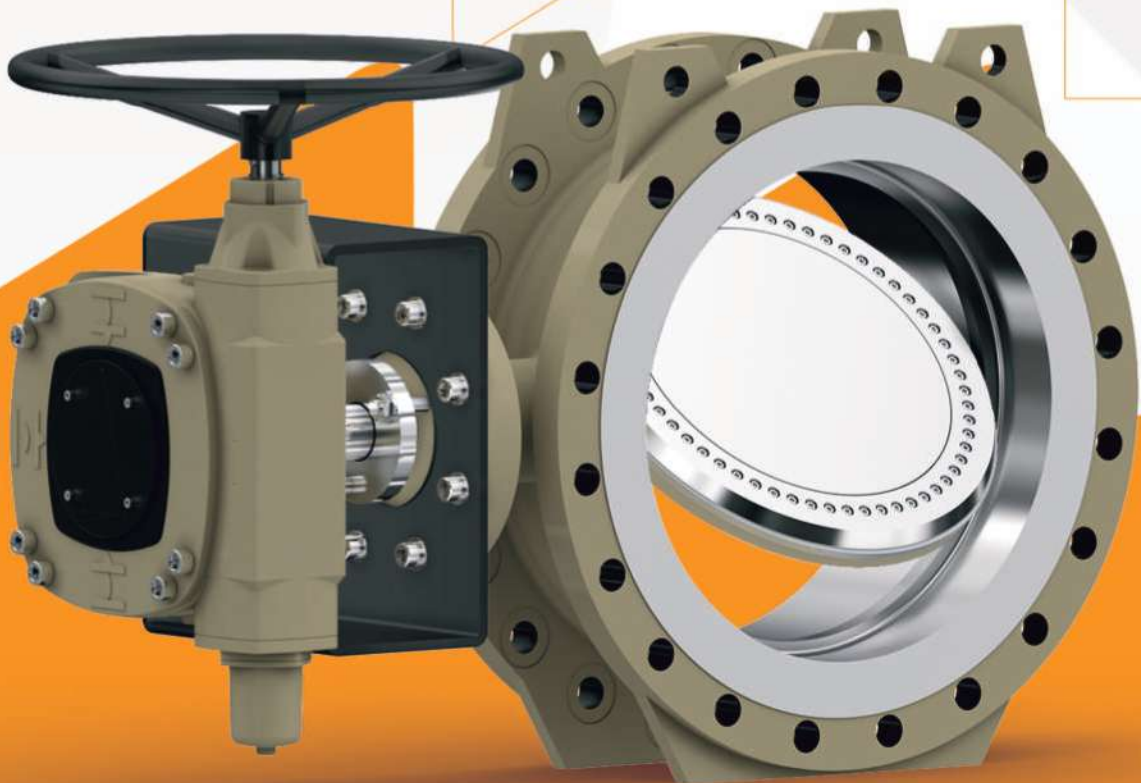

Originally founded in Germany in 1992, Magwen Valves has over 30 years of experience in delivering world-class valve solutions for the most challenging applications in key industries such as natural gas and petrochemicals (upstream to downstream), water infrastructure, chemical processing and energy production. After establishing its global presence from Germany, the company shifted operations to India, capitalizing on the country's promising economy, talent pool and manufacturing capabilities.



German Plant



India Plant

- **Magwen's product range is split into two categories:**

Isolation Valves

- Double Offset Butterfly Valves (3"-120"/DN80-DN3000 | up-to PN64/#300 pressure rating)
- Non-Slam Axial Flow Check Valves (2"-80"/DN50 - DN2000 | up-to PN250/#1500 pressure rating)
- 4 Function Non Slam Air Release Valves (0.5"-12"/DN15 - DN300 | up-to PN40/#300 pressure rating)
- Floating Ball Valves (0.5" - 8"/DN15 - DN200 | up-to PN50/#300 pressure rating)
- Trunnion Mounted Ball Valves (2"-50"/DN50-DN1400 | up-to PN420/#2500 pressure rating)

Control + Isolation Valves

- Triple Offset Butterfly Valves (4"-60"/DN100 - DN1500 | up-to PN420/#2500 pressure rating)
- Axial Flow Control (Plunger) Valves (4"-100"/DN100 - DN2500 | up-to PN420/#2500 pressure rating)
- Magwen Tri-Ball Valve (Full bore triple offset butterfly valve | 4" - 76"/DN100 - DN1900 | up-to PN420/#2500 pressure rating)

Our design philosophy rests on the following pillars:

Safe

- Operator
- Equipment
- Asset
- Society

Reliable

- Proven Technology
- Available on demand
- Peace of mind

Innovative

- Fit for use
- New Ideas
- Focussed on application

Efficient

- Time
- Total Cost of Ownership
- Lower Energy Consumption

The quality management systems for the production plant in India are certified as per ISO9001, ISO14001, and ISO45001. The product line is also certified as per PED, API 6D and API 609(with valid monogram licenses). All manufacturing processes that directly impact product performance can be done in-house. This includes state-of-the-art CNC machines for critical machining, in-house painting booths, and in-house testing facilities.



API 6D Monogram License



API 609 Monogram License



ISO 9001 Certificate



ISO 14001 Certificate



ISO 45001 Certificate



PED Certificate

• Triple Offset Design

Double offset butterfly valves show a significant performance increase over centric and single offset butterfly valves, owing to 'cam' type motion of the disc. However, they are not truly friction free. For approximately 50% of the operating motion, there exists slight contact between the seal and the valve seat. Because of this, double offset butterfly valves are given soft sealing systems that restrict the valve's ability to withstand high temperature and/or pressure. To overcome this problem, we give the valve a 3rd offset.

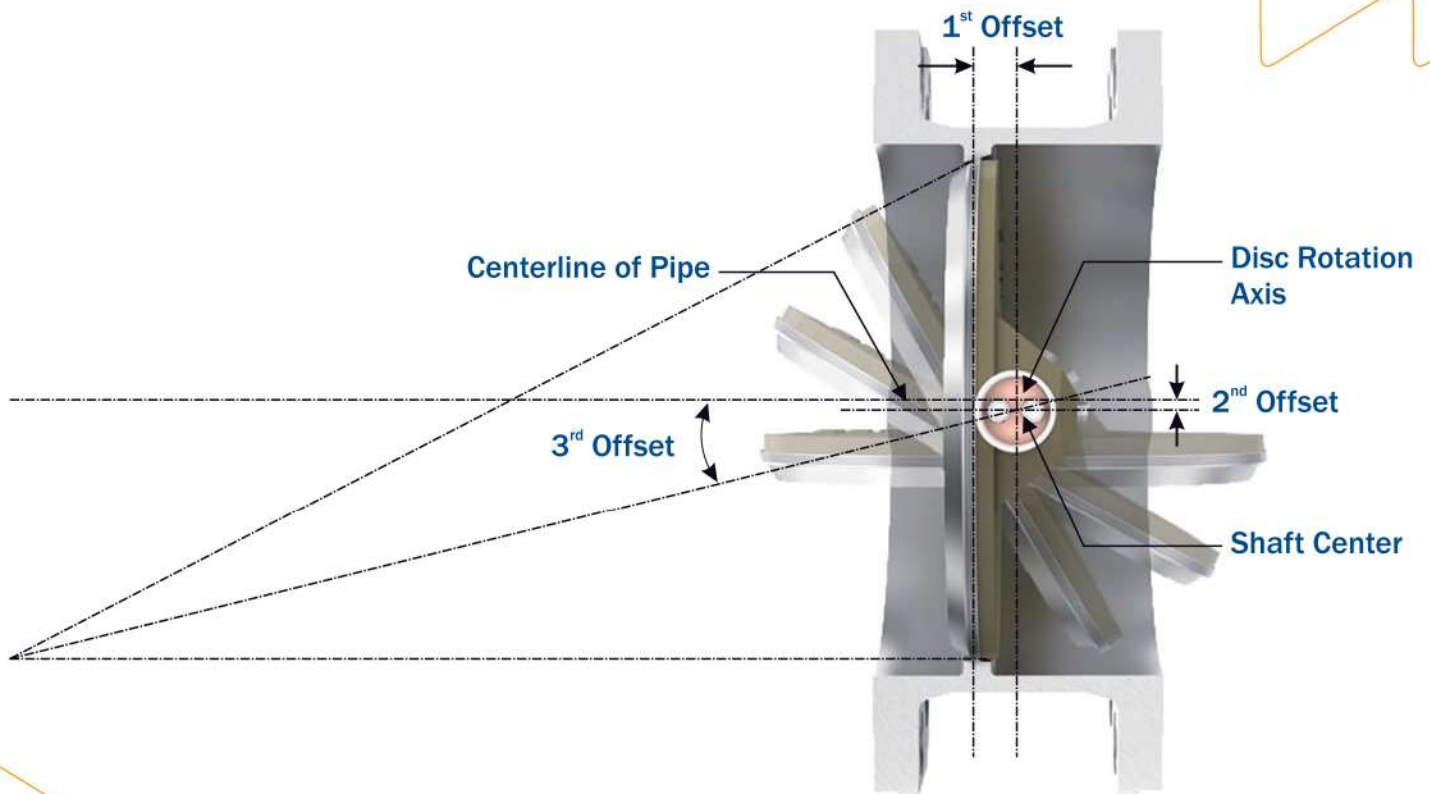

1st offset: The shaft's rotation axis is made offset from the disc's centerline

2nd offset: The shaft is made offset from the pipe centerline

3rd offset: The apex of the sealing cone is made offset by a certain angle from the pipe centerline

By giving the valve a third offset, friction between the seal and valve seat is nullified after just 0.5 degrees of rotation. Effectively, friction between seal and seat ring only occurs when the disc is fully closed: truly friction free operation. This gives the valve a far longer life span, with little to no maintenance required. The triple offset design uses metal sealing, which allows it to handle high media temperatures and pressures.

• Body Seat

The body seat is the stationary half of the valve's sealing system. We offer two design variations for body seat ring:

• Mechanical Rigidity

In this variation, the body seat ring is provided with a Stellite-21 weld overlay that is precisely machined to form triple offset sealing geometry.

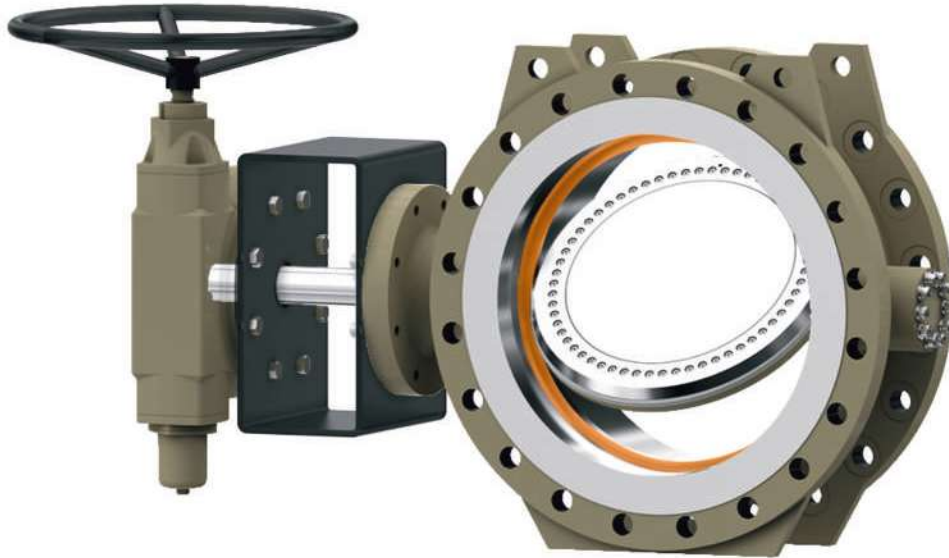

• PTFE Soft Seated

In this variation, we provide a 'soft' seat made using PTFE (Polytetrafluoroethylene). A ring of PTFE is placed in the valve body, acting as the seat ring. On the disc, a stainless-steel weld overlay is provided that is precisely machined to form triple offset sealing geometry. During assembly, a specialized in-house assembly procedure is followed which ensures that the PTFE seat ring's profile matches that of the machined disc. As a result, the valve is able to provide tight shut-off every time the disc is closed.



• Laminated Seal Ring



The seal ring is the moving half of the valve's sealing system. It is securely fastened to the disc with a retainer ring which combines the two into one robust, rigid unit. The seal ring's construction consists of alternate sheets of Duplex and graphite that are adhered together and precisely machined to generate the triple offset cone. This design makes the seal ring self-adjusting and resilient. When the disc is closed, the seal ring flexes and assumes the shape of the valve seat. The compression forces are equally distributed around the sealing perimeter, providing a tight, bi-directional seal. The resilient design of the seal allows the body seat to expand or contract due to temperature fluctuations, without the risk of jamming or localized leakages. Should the need arise, the seal ring is easily replaceable, minimizing process downtime for the user.



• Disc



The disc is engineered to be flow efficient. Its narrow profile is meant to minimize pressure drop and maximize flow.

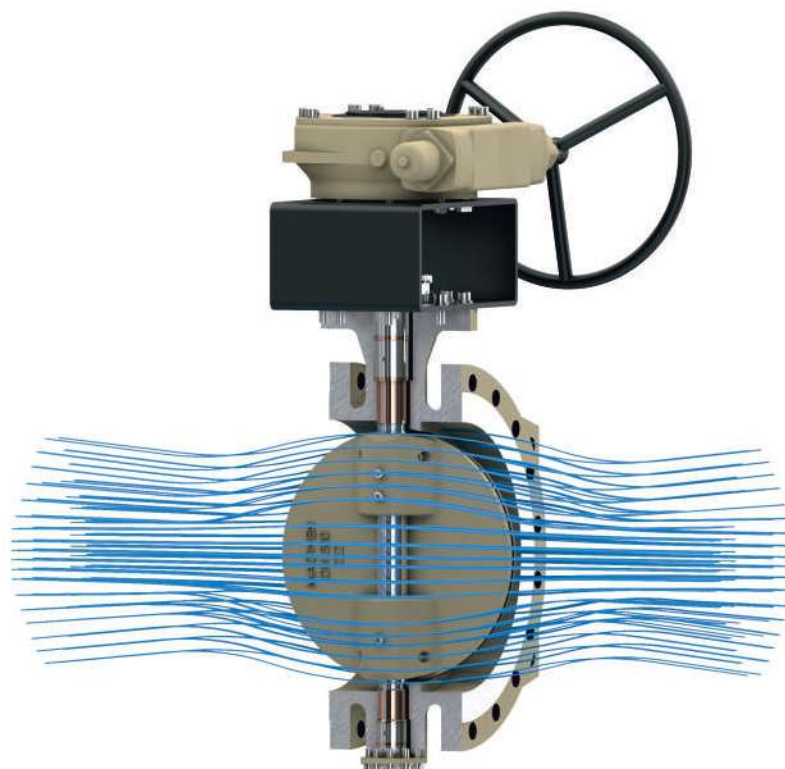

• Shaft to Disc Joint

The shaft is given a closed keyed connection to the disc. In doing so, hysteresis is minimized and stable operation of the valve is achieved. Axial movement of the disc is locked with the help of precision machined fasteners that securely hold it to the shaft.

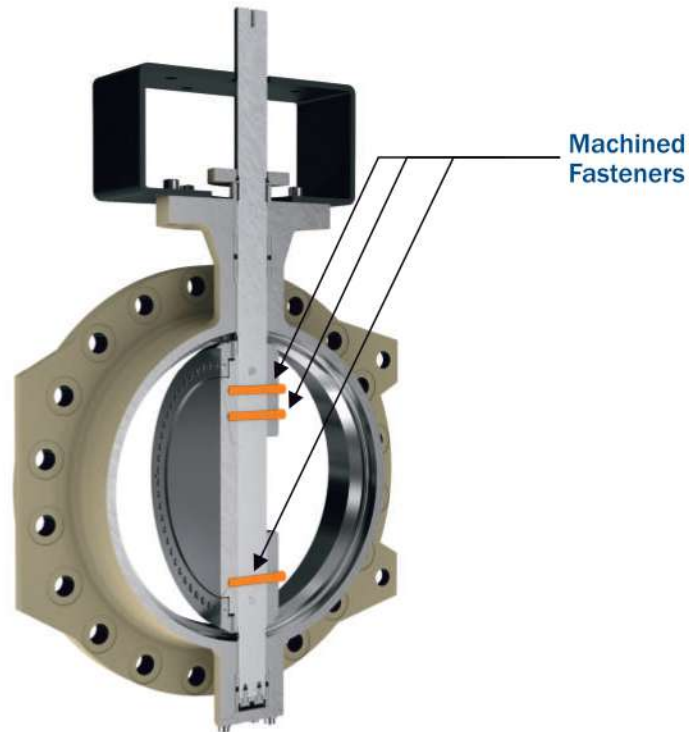

• Disc Position Indicator

On the outer face of the drive-end shaft, a dimple is provided that indicates the position of the disc: When the dimple is in line with the flow axis, the disc is in closed position.



• ISO Top Flange Bracket

The valve is provided with a bracket that complies to ISO standards, maximizing compatibility with all kinds of operators.

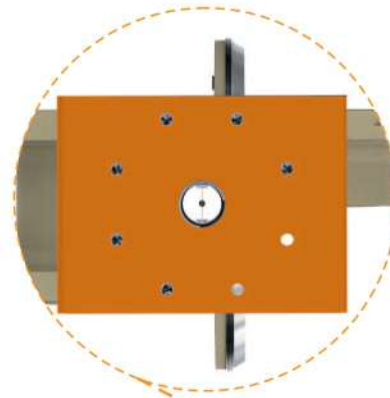

• Ingress Protection

The valve is provided with ingress protection arrangement for the shaft bearings, that completely blocks contact between line media and bearings. The arrangement prevents jamming of the shaft and preserves the life span of bearings.

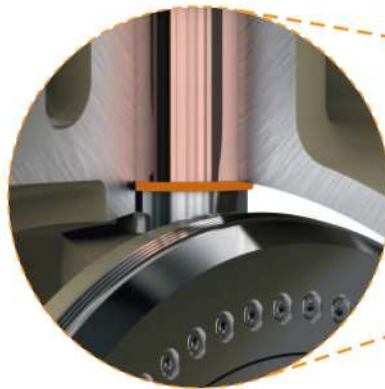

• Bearings

The shaft is supported using high precision stainless steel bearings with nitrating treatment. This process makes them capable of withstanding severe axial and radial loads, while being maintenance free.

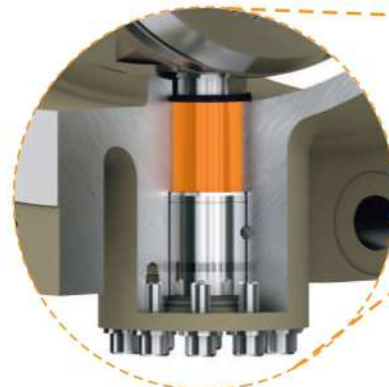

• Single Piece Shaft with Anti-Blowout Arrangement

The valve is provided with a single, robust shaft designed to meet NACE standards. The shaft is also provided with an anti-blowout arrangement. On the drive end side, the valve is provided with a snap ring that prevents axial movement of the shaft. On the non-drive end side, the shaft is given a collar that prevents shaft blow out under the severe pressure conditions in the line.

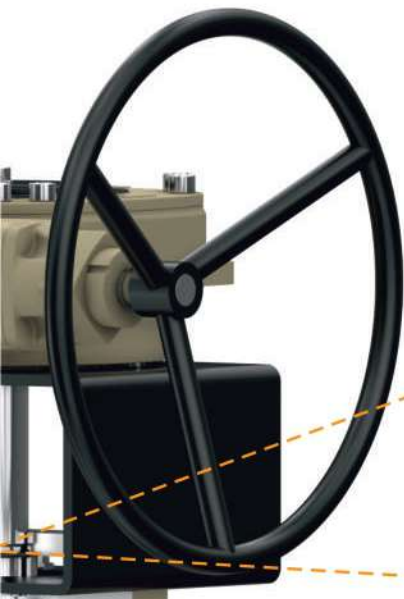

• Live Loaded Stem Packing

The sealing system for the shaft is provided with Belleville washers, making the system 'live loaded'. The spring action of the Belleville washers applies a constant load on the graphite packing material, effectively nullifying fugitive emissions.

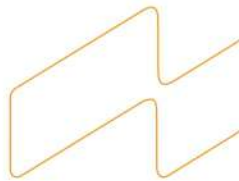
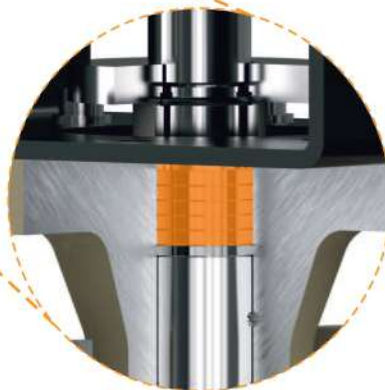

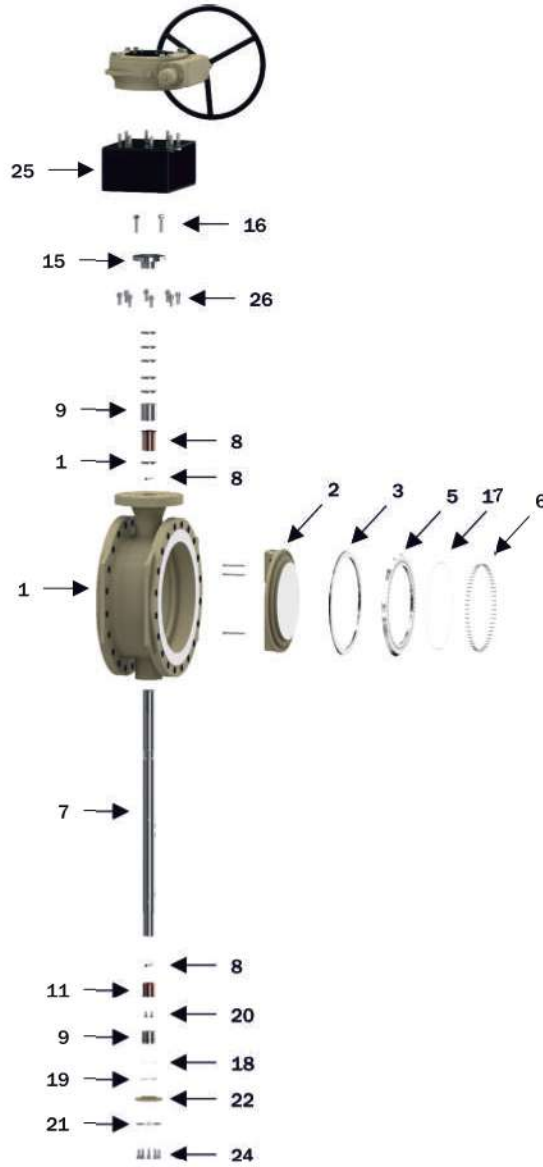

Component List - TOBV

Sr. No.	Part Name	Sr. No.	Part Name	Sr. No.	Part Name
1	Body	11	Packing Support Ring	21	Non-drive end Cover Gasket
2	Disc	12	Gland Packing	22	Non-drive end cover
3	Seal Ring (Laminated/ Soft Seat)	13	Gland	23	Non-drive end Cover - Spring Washer
4	Seal Gasket	14	Stem Retainer	24	Non-drive end Cover Bolts
5	Retainer Ring	15	Gland Flange	25	Bracket
6	Retainer Ring Screws	16	Stud & Nut -Gland Flange/ Bolts	26	Fasteners (Bracket)
7	Shaft	17	Bellewille Washer / Washer		
8	Key	18	Non-drive end Side thrust PAD Bearing		
9	Bearing	19	Non-drive end Side TH. PAD Support Spacer		
10	Ingress Progress Packing	20	Non-drive end Side Blow out Proof Screws		

Materials Offered				
Sr. no	Component Name	Carbon Steel	Stainless Steel	
1	Body	ASTM A216 GR.WCB / WCC + ST.21 ASTM A352 GR. LCB / LCC + ST.21	ASTM GR. GR. CF8M / CF3M + ST.21	Other materials may be available on request
2	Disc	ASTM A216 GR.WCB / WCC ASTM A352 GR. LCB / LCC	ASTM GR. GR. CF8M / CF3M	
3	Seal Ring (Laminated) / Soft Seat	UNS S31803 (Duplex)+ Graphite UNS S20910 (XM-19)+ Graphite UNS N06625 (Inconel)+ Graphite	UNS S31803 (Duplex)+ Graphite UNS S20910 (XM-19)+ Graphite UNS N06625 (Inconel)+ Graphite	
4	Seal Gasket	Graphite / SS316 With Graphite / SS316L With Graphite		
5	Retainer Ring	ASTM A516 Gr.70	ASTM A240 Type SS316 / ASTM A240 Type SS316L	Other materials may be available on request
6	Retainer Ring Screws	ISO 3506 A4-70 / ASTM A193 Gr. B8M-CL 2	ISO 3506 A4-70 / ASTM A193 Gr. B8M-CL 2	
7	Shaft	ASTM A479 Type 410 Condition 3 / ASTM A564 Type 630 (H1150D)	ASTM A564 Type 630 (H1150D) / ASTM A182 GR.F55	
8	Key	ASTM A479 Type 410 Condition 3 / ASTM A564 Type 630 (H1150D)	ASTM A564 Type 630 (H1150D) / ASTM A182 GR.F55	
9	Bearing	SS316 (Hard Faced) / SS316L (Hard Faced)		
10	Ingress Progress Packing	Graphite		
11	Packing Support Ring	ASTM A479 Type SS316 / SS316L		
12	Gland Packing	Graphite		
13	Gland	ASTM A479 Type SS316 / SS316L		
14	Stem Retainer	ASTM A313 Type 302		
15	Gland Flange	ASTM A516 Gr. 70	ASTM A240 Type SS316	Other materials may be available on request

Materials Offered					
Sr. no	Component Name	Carbon Steel	Stainless Steel		
16	Stud & Nut -Gland Flange/ Bolts	STUD : ASTM A193 Gr. B7, NUT : ASTM A194 Gr. 2H	STUD: ASTM A193 Gr. B8M-CL 2 NUT : ASTM A194 Gr. 8M	Other materials may be available on request	
17	Bellewille Washer/ Washer	ASTM A240 Type SS316			
18	NDE Side thrust PAD Bearing	ASTM A479 Type SS316 / SS316L -Hard Faced	ASTM A479 Type SS316 / SS316L -Hard Faced	Other materials may be available on request	
19	NDE Side TH. PAD Support Spacer	ASTM A479 Type SS316 / SS316L -Hard Faced	ASTM A479 Type SS316 / SS316L -Hard Faced		
20	NDE Side Blow out Proof Screws	ASTM A193 Gr. B8M-CL 2	ISO 3506 A4-70 / ASTM A193 Gr. B8M-CL 2		
21	NDE Cover Gasket	Graphite / SS316 With Graphite / SS316L With Graphite			
22	NDE cover	ASTM A516 Gr.70 / ASTM A36	ASTM A240 Type SS316 / ASTM A240 Type SS316L		
23	NDE Cover - Spring Washer	Spring Seel			Other materials may be available on request
24	NDE Cover Bolts	ASTM A193 Gr. B7	ISO 3506 A4-70 / ASTM A193 Gr. B8M-CL 2	Other materials may be available on request	
25	Bracket	CS + Black Powder Coat			
26	Bracket - BOLTS	ASTM A193 Gr. B7	ISO 3506 A4-70 / ASTM A193 Gr. B8M-CL 2	Other materials may be available on request	

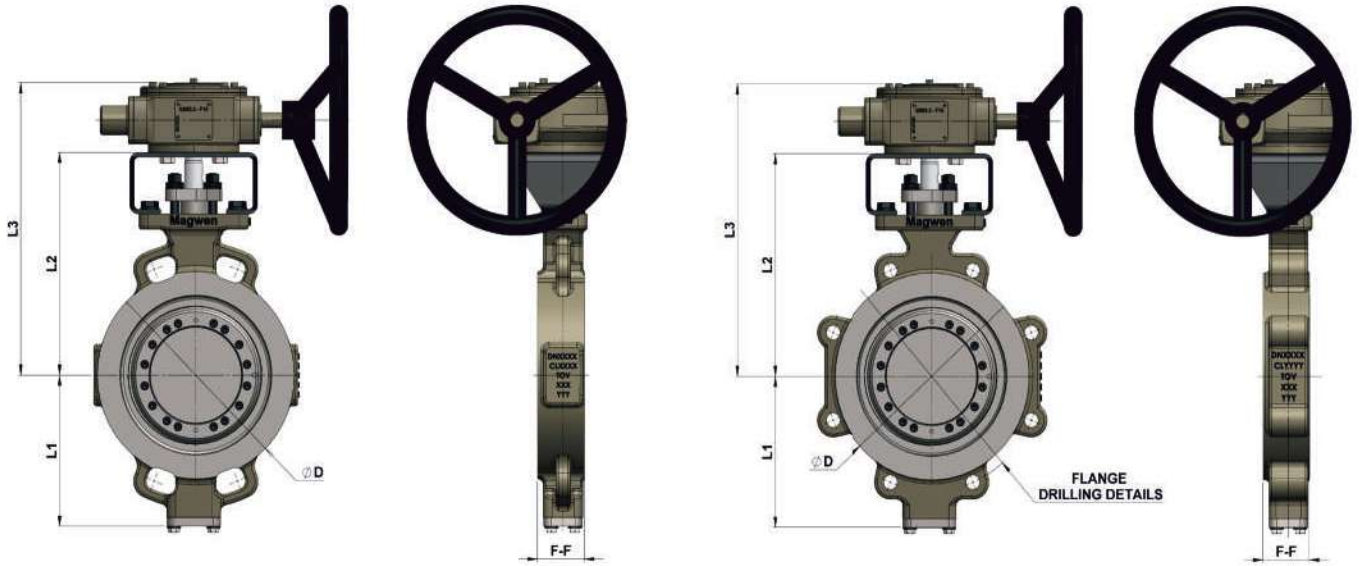

Wafer Type

Lug Type

#150										
Sizes		d _h	n	D	PCD	L ₁	L ₂	F-F	Weight (Kg)	
DN	NPS								Wafer Type	Lug Type
80	3	19.1	4	127	152.4	125	190	48	9	11
100	4	19.1	8	157	190.5	143	220	54	15	17
150	6	22.2	8	216	241.3	184	270	57	18	26
200	8	22.2	8	270	298.4	197	290	64	29	39
250	10	25.4	12	324	362	197	355	71	45	58
300	12	25.4	12	381	431.8	270	385	81	73	91
350	14	28.6	12	413	476.2	295	410	92	97	123
400	16	28.6	16	470	539.8	325	480	102	123	190
450	18	31.8	16	534	577.8	375	510	114	164	237
500	20	31.8	20	584	635	405	555	127	220	317
600	24	34.9	20	692	749.3	470	645	154	324	489

NOTE: For dimension 'L3' and data regarding sizes above DN600, please contact us.

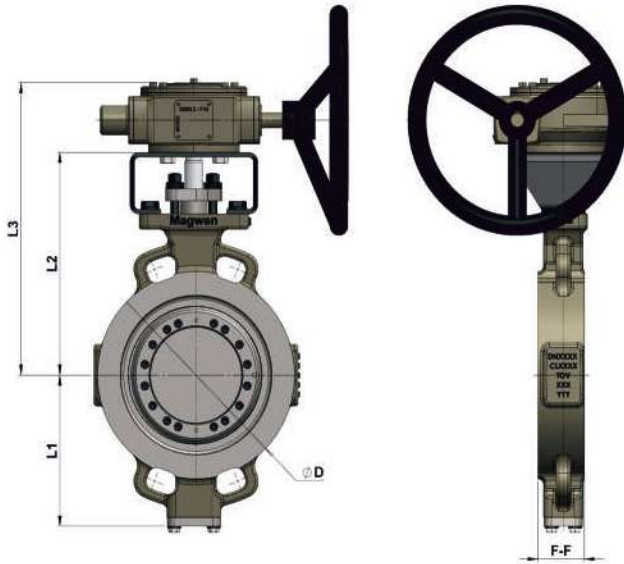

Wafer Type

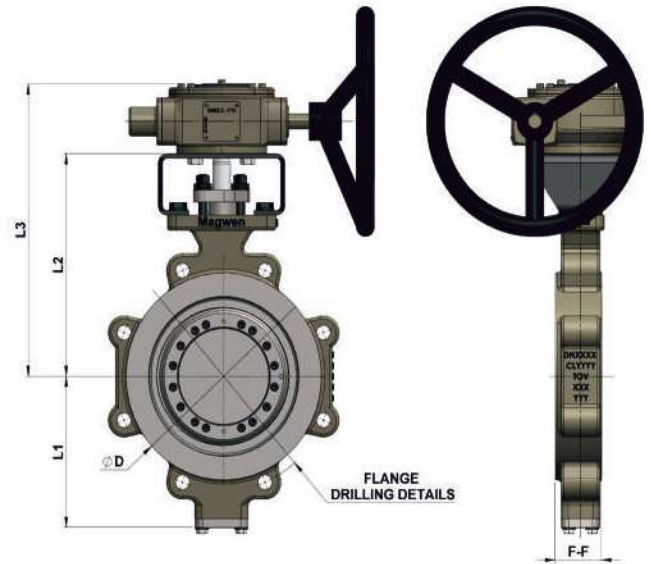

Lug Type

#300										
Sizes		d_h	n	D	PCD	L_1	L_2	F-F	Weight (Kg)	
DN	NPS								Wafer Type	Lug Type
80	3	22	8	127	168	125	190	48	9	12
100	4	22	8	157	200	143	220	54	15	22
150	6	22	12	216	270	184	270	59	18	31
200	8	25	12	270	330	235	325	73	50	51
250	10	29	16	324	387	255	375	83	75	84
300	12	32	16	381	451	290	430	92	109	123
350	14	32	20	413	514	335	480	117	165	235
400	16	35	20	470	572	365	535	133	228	320
450	18	35	24	534	629	420	600	149	285	434
500	20	35	24	584	686	460	640	159	390	512
600	24	41	24	692	813	525	750	181	525	788

NOTE: For data regarding sizes above DN600, please contact us.

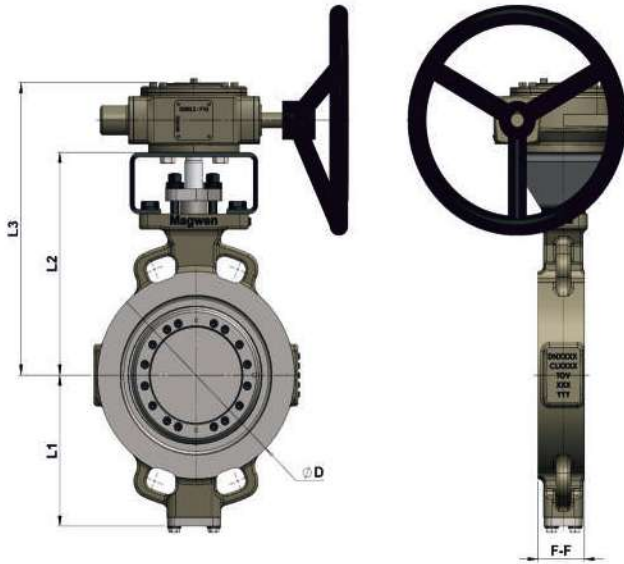

Wafer Type

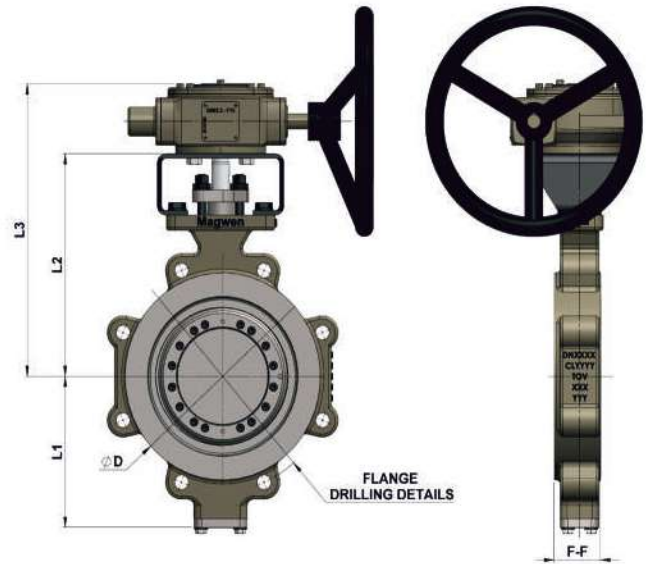

Lug Type

#600										
Sizes		d _h	n	D _r	PCD	L ₁	L ₂	F-F	Weight (Kg)	
DN	NPS								Wafer Type	Lug Type
80	3	22	8	146	168.1	135	235	54	14	18
100	4	25	8	175	215.9	185	300	64	25	30
150	6	29	12	241	292.1	195	315	78	65	70
200	8	32	12	302	349.2	265	405	102	90	100
250	10	35	16	350	431.8	330	485	117	135	185
300	12	35	20	413	489	365	535	140	220	255
350	14	38	20	457	527	390	610	155	285	325
400	16	41	20	508	603.2	440	665	178	450	515
450	18	45	20	575	654	460	710	200	550	630
500	20	45	24	635	723.9	525	795	216	690	800
600	24	51	24	749	838.2	625	885	232	1085	1240

NOTE: For data regarding sizes above DN600, please contact us.

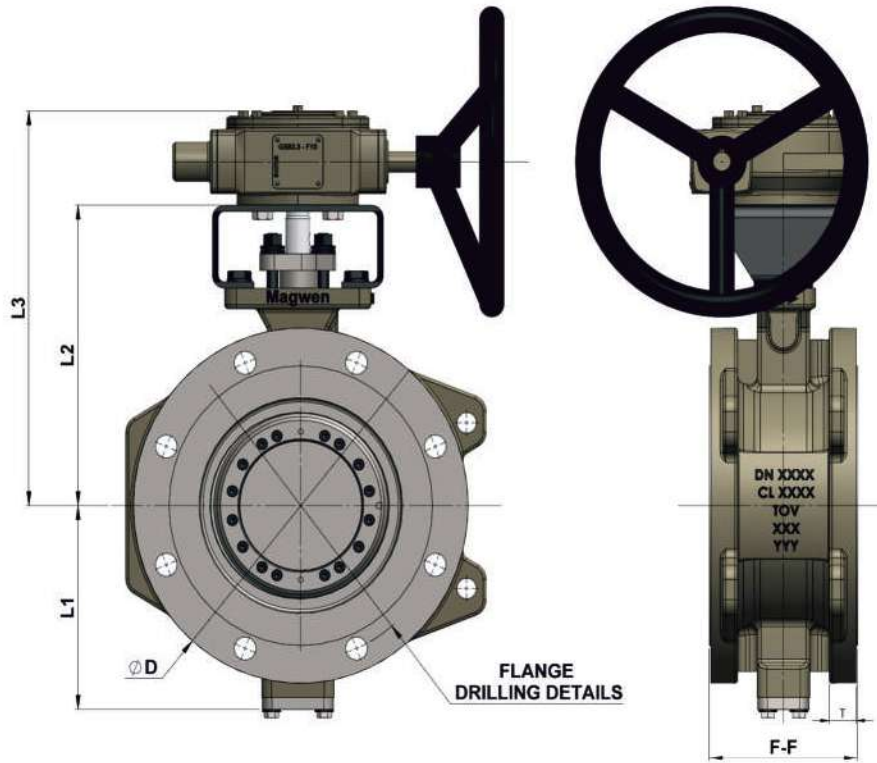

Double Flanged

#150

Sizes		d _h	n	D	PCD	L ₁	L ₂	F-F		Weight (Kg)	
DN	NPS							Short Pattern	Long Pattern	Short Pattern	Long Pattern
80	3	19.1	4	190	152.4	125	190	114	203	18	20
100	4	19.1	8	229	190.5	143	220	127	229	28	30
150	6	22.2	8	279	241.3	184	270	140	267	40	42
200	8	22.2	8	343	298.4	197	290	152	292	62	65
250	10	25.4	12	406	362	245	355	165	330	85	95
300	12	25.4	12	483	431.8	270	385	178	356	128	150
350	14	28.6	12	533	476.2	295	410	190	381	170	200
400	16	28.6	16	597	539.8	325	480	216	406	217	250
450	18	31.8	16	635	577.8	375	510	222	432	295	328
500	20	31.8	20	693	635	405	555	229	457	372	407
600	24	34.9	20	813	749.3	470	645	267	508	550	606
700	28	34.9	28	925	863.6	520	720	292	610	870	975
750	30	34.9	28	985	914.4	560	830	318	610	1380	1590
800	32	41.3	28	1060	977.9	600	870	318	660	1560	1800
900	36	41.3	32	1170	1085.8	640	915	330	711	1880	2160
1000	40	41.3	36	1290	1200.2	700	980	410	Available on request	2430	Available on request
1050	42	41.3	36	1345	1257.3	825	1110	410		2875	
1100	44	41.3	40	1405	1314.4	835	1140	470		3180	
1200	48	41.3	44	1510	1422.4	850	1250	470		3500	

NOTE: For data regarding sizes above DN1200, please contact us.

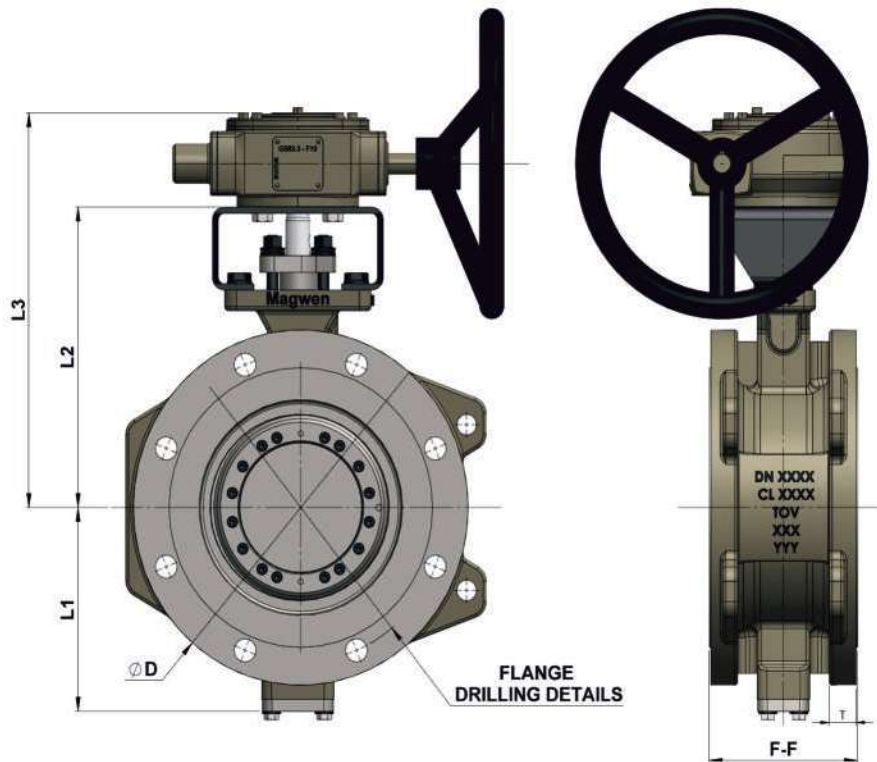

Double Flanged

#300												
Sizes		T	d _h	n	D	PCD	L ₁	L ₂	F-F		Weight (Kg)	
DN	NPS								Short Pattern	Long Pattern	Short Pattern	Long Pattern
80	3	26.9	22.2	8	210	168.1	125	190	114	282	20	22
100	4	30.2	22.2	8	254	200.2	143	220	127	305	34	38
150	6	35.1	22.2	12	318	269.7	184	270	140	403	56	64
200	8	39.6	25.4	12	381	330.2	235	325	152	419	86	102
250	10	46	28.6	16	444	387.1	255	375	165	457	130	154
300	12	49.3	31.8	16	521	450.8	290	430	178	502	182	210
350	14	52.3	31.8	20	584	514.4	335	480	190	762	269	323
400	16	55.6	34.9	20	648	571.5	365	535	216	838	405	544
450	18	58.7	34.9	24	711	628.6	420	600	222	914	525	744
500	20	62	34.9	24	775	685.8	460	640	229	991	605	873
600	24	68.3	41.3	24	914	812.8	525	750	267	1143	905	1360

NOTE: For data regarding sizes above DN600, please contact us.

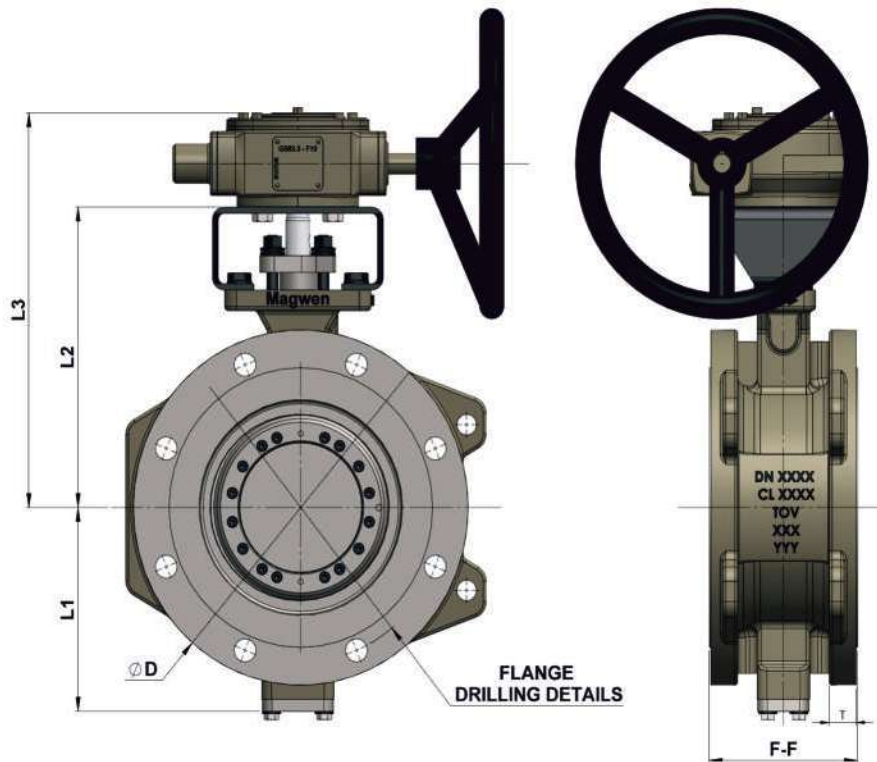

Double Flanged

#600												
Sizes		T	d _h	n	D	PCD	L ₁	L ₂	F-F		Weight (Kg)	
DN	NPS								Short Pattern	Long Pattern	Short Pattern	Long Pattern
80	3	31.8	22.2	8	210	168.1	136	235	180	356	41	45
100	4	38.1	25.4	8	275	215.9	185	300	190	432	65	70
150	6	47.8	28.6	12	355	292.1	195	315	210	559	132	150
200	8	55.6	31.8	12	420	349.2	265	405	230	660	160	190
250	10	63.5	34.9	16	510	431.8	330	485	250	787	266	320
300	12	66.5	34.9	20	560	489	365	535	270	838	365	425
350	14	69.8	38.1	20	605	527	390	610	290	889	490	555
400	16	76.2	41.3	20	685	603.2	440	665	310	991	700	865
450	18	82.6	44.5	20	745	654	460	710	330	1092	735	970
500	20	88.9	44.5	24	815	723.9	525	795	350	1194	870	1200
600	24	101.6	50.8	24	940	838.2	625	885	390	1397	1420	1975

NOTE: For data regarding sizes above DN600, please contact us.

List of Standards Followed

Sr. no	Scope	Standard Followed
1	Design Standards	API609
		ASME B16.34
		BS EN 593
2	Testing Standards	API598
		ISO5208
		BS EN 1226-1
3	Face to Face Standards	API-609 Category B
		BS EN 558
		ASME B16.10
		ISO5752
4	Flange Drilling Standards	ASME B16.5
		ASME B16.47
		BS EN1092-1
5	NACE Standards	ASME MR 0103/ 0175
		ISO 15156-1
6	Fire Safe Norms	API 607
		ISO 10497
7	Fugitive Emission Norms	API 641
		ISO 15848

VALVE SOLUTIONS AFRICA

+27(0) 82 416 4959

sales@valvesolutions.co.za

17 Resnick Street, Factoria,
Krugersdorp, 1739

valvesolutions.co.za